

How to Plan for Mixer Blender Parts

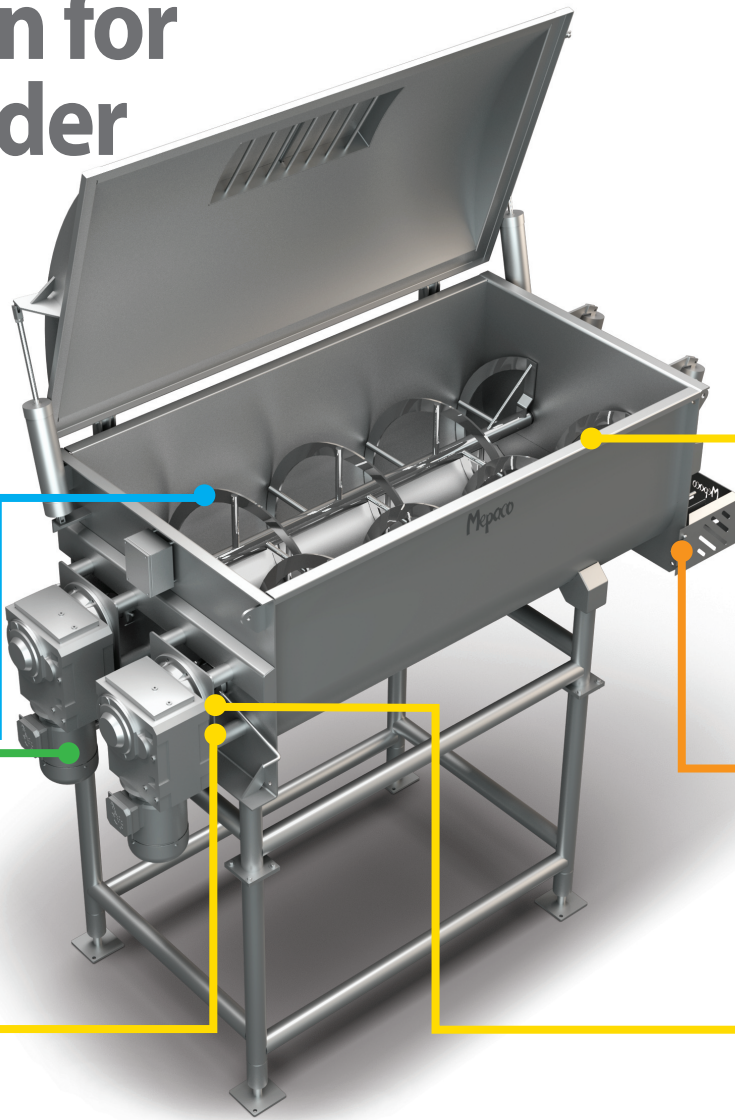

Motors
Extra motors can prevent unnecessary emergency shut-downs and lost production
EMERGENCY

Agitators
Custom fabricated, requiring longer lead time for assembly, welding, and finishing
LONG LEAD TIME

Drive Shaft Seal
Plan for 2 - 3 seals in your parts inventory, depending on usage
PREVENTATIVE MAINTENANCE

Cylinders
Plan ahead with back ups of cylinders, they can be a long lead time part
LONG LEAD TIME

Discharge Bearing
Recommend 1 or 2 for back ups. If bearing is not a stock item, plan for additional lead time
RECOMMENDED SPARES

Discharge Shaft Seal
Plan for 2 - 4 seals in your parts inventory program, depending on usage
PREVENTATIVE MAINTENANCE

Cover Gasket
Gasket material for covers are sold by the foot
PREVENTATIVE MAINTENANCE

Safety Switches
Inventory extra safety switches to reduce down-time
RECOMMENDED SPARES

Seal Housing Gasket
Keep 2 - 3 seals in your parts inventory, comes in bulk sections
PREVENTATIVE MAINTENANCE

Air Cylinder Seal Kit
Plan for 2 - 3 seals in your parts inventory, depending on usage
PREVENTATIVE MAINTENANCE

Discharge Door Gasket
Usually sold in bulk by the foot
PREVENTATIVE MAINTENANCE

Mepaco
920.356.7347
www.mepaco.net